

## Nanjing Langshi o he ya yuan Xihuafu

by / 2018-06-13 08:32:04 / China / 7476 / CN

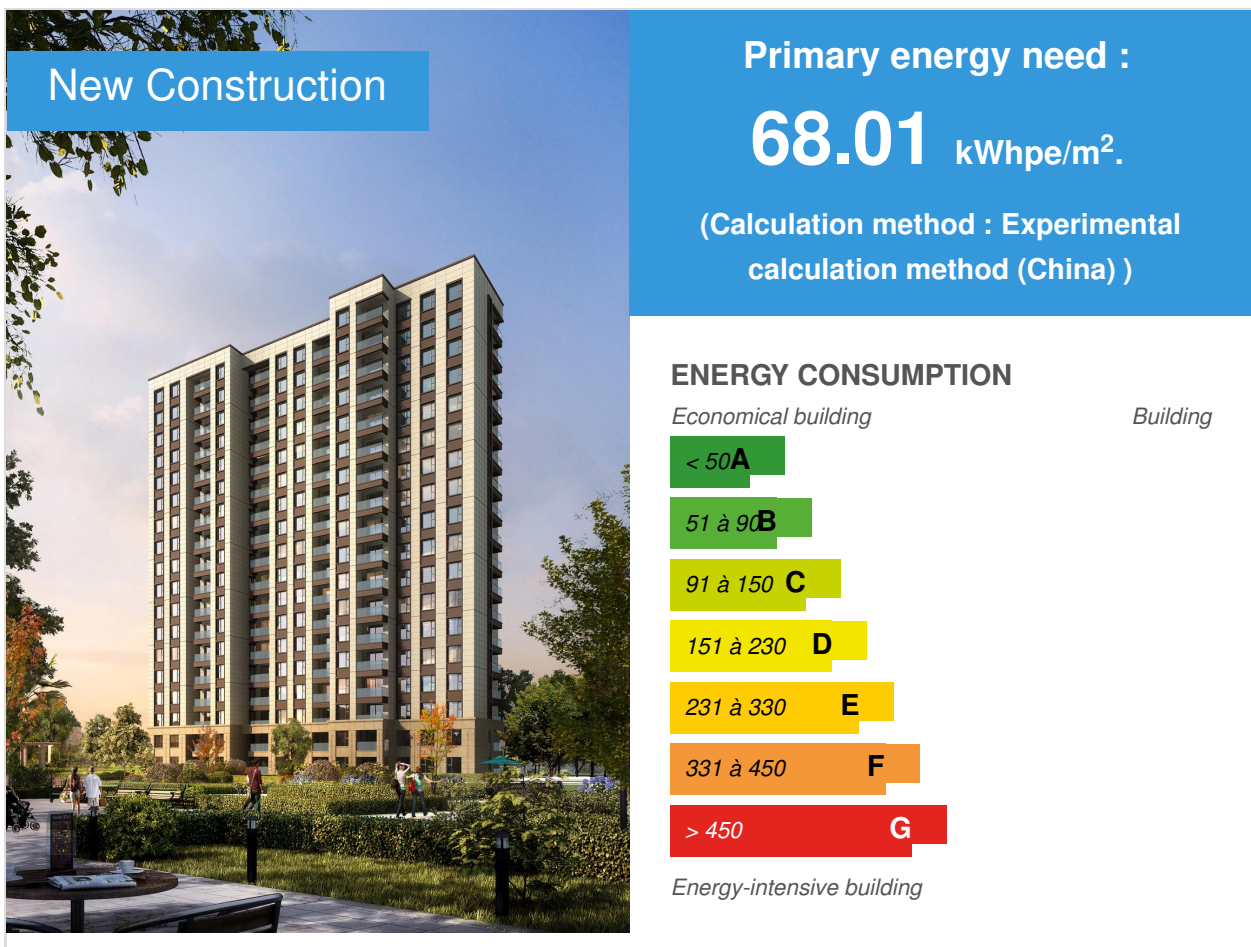

**Building Type** : Collective housing < 50m

**Construction Year** : 2015

**Delivery year** : 2018

**Address 1 - street** : 210019 ,

**Climate zone** :

**Net Floor Area** : 202 595 m<sup>2</sup>

**Construction/refurbishment cost** : 200 000 000 ¥

**Cost/m<sup>2</sup>** : 987.19 ¥/ m<sup>2</sup>

#### Certifications :



## General information

1. Engineering nature: this project is residential building.
2. Engineering investment: the total investment of the project is about 200 million yuan.
3. land area: project area 55666.61m<sup>2</sup>
4. structural form: the construction of this project adopts reinforced concrete shear wall structure.
5. major technical issues to be addressed:

The project design, combined with the local climate in Nanjing and the characteristics of the building itself, choose the green ecological energy-saving technology matched with it. High efficiency cold and heat source equipment and ground source heat pump system are used in HVAC system to reduce heating energy consumption. Ground source heat pump units provide all household water for the project. The rainwater reuse scheme is adopted to save water resources. Energy-saving buildings that meet the requirements of green buildings are constructed from six aspects: land saving, energy saving, water saving, material saving, indoor environmental quality, improvement and innovation.

1 Building and enclosure structures: The building energy efficiency rate of this project is 75%.The energy-saving ratio of envelope has been increased by more than 25% of design standard JGJ134-2010 for residential buildings in hot summer and cold winter areas.It will greatly improve the energy efficiency of building envelope and reduce building energy consumption.

2 Pervious ground: Pervious ground is set outside the building of this project, including pervious brick, grass grid pervious asphalt ground, etc. The total area of the outdoor permeable ground is 9229.8 square meters, which accounts for 50.59% of the total area of the

outdoor pavement.

3 Runoff control: Through the use of pervious surface, concave green space, rainwater recovery system, the site rainwater runoff control rate reached more than 70%.

4 Ground source heat pump system: Five ground source heat pump units are used in this project, and one screw refrigeration unit is provided by cooling tower. The 5 ground source heat pump units are refrigerant 1211.4kW and heat 1212.7kW. The refrigerating capacity of 1 screw refrigeration units is 1587Kw. The proportion of ground source heat pump to provide air-conditioning cooling and heating accounts for 88.42%. At the same time, two high-temperature heat pumps are installed in the ground source room to make 60 C domestic hot water for all residents in the residential area to use domestic hot water.

5 Efficient cold and heat source: The COP of the cold and heat source units in this project is more than 12% higher than the standard GB50189 of "Energy Saving Design Standard for Public Buildings", which can effectively save energy consumption of air conditioning system.

6 Main room air handling measures: The new fan is a new air handling unit with full heat recovery device the new fan unit is equipped with return fan section, initial/intermediate/sub-high efficiency filtration section, total heat recovery section, surface cooling and humidification section, fan section, muffling section, maintenance intermediate section and other functional sections. Fresh air system can create indoor thermal environment with suitable temperature and humidity and comfortable environment by filtering and purifying fresh air, heat recovery and humidification. The filtering efficiency of PM2.5 can reach 95%.

7 The proportion of recyclable materials used in this project to the total weight of building materials is 6.91%, which can effectively save building materials.

8 Controlling indoor formaldehyde, VOC, benzene and other pollutant concentrations through design optimization, source control, special testing and construction management are far superior to the United States and China standards, which are in line with the world's most stringent Finnish S1 standards.

## Data reliability

Self-declared

## Stakeholders

## Contractor

Name :

Contact : xuyanmei@landsea.cn

## Construction Manager

Name :

## Contracting method

General Contractor

## Owner approach of sustainability

**Objective:** This Project is the first product of passive architecture used by Landsea and Nanjing's first super clean fresh air system project, which the total displacement of fresh air system is 100% and the three level filtration efficiency is 95%. The formaldehyde content in the finely decorated room is less than 0.03 mg per cubic meter according to the world's most stringent Finnish S1 standard.

**Measures:** Kitchen air microcirculation system, Electric sunshade curtain 4 big pocket parks Integrated smart home Ultra clean fresh air Yijia small station Wide panoramic window Sewerage in the same layer Indoor air quality instant monitoring system Five star hotel standard double Hall 24 hours central hot water Seven storage systems Ceiling radiation Art Library Ground source heat pump 800 meter healthy runway the community Bookstore 24 hours without closing Aerial class living room lifting push pull door.

**Target** reate a passive green building with ultra-clean fresh air, ground-source heat pump, ceiling radiation, ultra-low formaldehyde and intelligent display, to ensure the health of residents as a starting point, interpretation of Landsea "comfortable, healthy, energy-saving, environmental protection, intelligent" customer value.

## Architectural description

### 1 Passive exterior enclosure system for buildings

Insulation Excellent thermal insulation performance, the building energy saving rate is designed according to 75%.

Low carbon energy saving Compared with ordinary high-end residential energy-saving efficiency of 20% - 30%, greatly saving home electricity, gas and other energy costs;

Low-noise living: indoor noise control within 40 decibels, with a deeper sleep and "super quiet" space use environment;

Efficient anti-haze: High air-tightness building features, can be compared with ordinary residential 3-4 times improvement of the effect of haze removal, sanitary dead corner will not be full of dust.

## 2 Ground source heat pump, ceiling radiation, replacement of fresh air and efficient filtration system

The active energy-saving technology of ground-source heat pump and ceiling radiation is adopted, which can save energy and achieve good temperature sensation at the same time. The total replacement of fresh air system can effectively control PM2.5 by three level filtration. The airflow of the upper and lower airflow, the uniform and slow wind speed, makes the customer no feeling of blowing. At the same time, it can ensure that the indoor temperature is between 20-26 C, the relative humidity is between 30-70%, and the indoor air is completely replaced every 1.5 hours. Achieving these comfortable health indicators is also significantly lower the energy consumption than that of conventional buildings.

## 3 Finland S1 formaldehyde control system

The indoor decoration of the project reaches Finland S1 formaldehyde control standard (less than 0.03mg/m). And from the source to control the formaldehyde content, control and monitor the material before and after the construction, delivery can be checked in.

Xihuafu has multiple material selection, complex production and installation technology. Under the premise of achieving high standard indoor decoration effect, all the units in the area reach the Finnish S1 formaldehyde control standard (formaldehyde content < 0.03mg/m<sup>3</sup>).

## 4 Landsea information system

Omni directional real-time monitoring: Real time monitoring of indoor and outdoor air quality, timely adjustment of indoor environment gives owners a healthy and comfortable living environment.

Comprehensive security guard: internal and external security system to create a safe community.

Mobile terminal remote control: to achieve remote control of mobile phones, to keep abreast of and control the situation at home.

## 5 Comprehensive utilization system of water resources

The water tank is equipped with UV sterilizing apparatus, to ensure that the effluent quality is better than the "Hygienic standard for drinking water" GB 5749 requirements.

The basement is equipped with 200 cubic meters of rainwater pool to collect rainwater for green sprinkler irrigation, site irrigation and garage flushing.

4 direct drinking stations are set up outside the room to provide direct drinking water service for outdoor activities.

## 6 Kitchen microcirculation system

Avoid the fume smell (by linking with the fume machine, when the fume machine is opened, the corresponding fresh air is added from the outdoor, so that the pressure in the kitchen is balanced and the fume from the cooking table is wrapped in the fume machine and discharged into the flue to avoid the fume smell).

## 7 BIM innovative design

The project uses BIM modeling technology to analyze and optimize the collision of some mechanical and electrical pipelines in the underground garage of the plot. Navisworks collision report is formed, collision problems and adjustment schemes of mechanical and electrical pipelines are analyzed, cable bridge, wind pipe and electric pipe layout and direction are optimized, and related problems in the follow-up construction process are effectively avoided.

### If you had to do it again?

Dehumidification (anti condensation) in public areas

#### ▲ Objective:

to reduce the risk of condensation in the public area and improve the overall comfort of the building. Set up fan coil units for the Project.

#### ▲ Design principles:

1 The fan coil unit is equipped with one floor, middle floor (for example, 30 stories, 15 stories in the middle) and top floor, Whether the other floors are set up according to the specific circumstances of the project.

2 The cold and hot water supply and return water of fan coil unit is supplied by the fresh air system.

3 The fan coil unit is designed to meet the demand of dehumidification, and the number of ventilation in the front chamber is checked.

4 The speed of sending and exhausting air should be lower than 3m/s, avoiding the strong wind blow feeling caused by high wind speed.

5 Fan coil condensate causes indirect discharge in plumbing shaft.

#### ▲ Control points

1 Fan coil units calculate refrigerating capacity and heat production.

2 The design speed of fan coil delivery and outlet is designed.

3 The slope direction and ceiling height of condensate.

4 Fan coil unit installation ceiling space.

Dry ground wetting

#### ▲ Objective

In order to better solve the problem of "first floor is not hot", enhance the indoor comfort of the first floor, improve the heat transfer efficiency of the first floor heating. The improvement of the first floor method is changed from overhead to solid, namely dry to wet.

#### ▲ Design principles

The floor of the first floor of a residential building or the lower part of which is non residential shall be floor heating.

#### ▲ Control points

(1) when the first floor has no basement, the base should be moistureproof.

(2) the gap between the pipeline and the extruded plate is filled with polyurethane foam.

(3) when the fine stone concrete layer is laid, the raw slurry should be smoothed out.

### Building users opinion

To buy a house, I used to care about which road the house lived on, how much space the apartment had, how high the standard of decoration was, and whether there was a big international brand in the assembly. But the house is still occupied by people, so good health is the most important thing to live in. Nanjing Xihuafu as a national green building certification project, it has realized the control of indoor formaldehyde, VOC, PM2.5 concentration and other pollutants, intelligent control of constant temperature and humidity, application of clean energy and control of sound insulation and noise reduction. Create a healthy and comfortable technology residence, so that the home warm in winter and cool in summer, the four seasons such as spring, fresh air, sufficient sunshine, but also enjoy the quiet living space.

## Energy

### Energy consumption

Primary energy need : 68,01 kWhpe/m<sup>2</sup>.

Primary energy need for standard building : 95,16 kWhpe/m<sup>2</sup>.

Calculation method : Experimental calculation method (China)

Final Energy : 68,01 kWhfe/m<sup>2</sup>.

Breakdown for energy consumption :

HVAC: 54.34Kwh/m2/year

General lighting socket equipment: 13.67Kwh/m2/year

### Envelope performance

Envelope U-Value : 0,40 W.m<sup>-2</sup>.K<sup>-1</sup>

More information :

Roof: 0.39W.M-2.K-1

Window: 2.4W.M-2.K-1

Building Compactness Coefficient : 0,30

Indicator : GB/T 7106-2008

Air Tightness Value : 6,00

### Real final energy consumption

Real final energy consumption/m<sup>2</sup> : 30,75 kWhfe/m<sup>2</sup>.

## Renewables & systems

## Systems

### Heating system :

- Geothermal heat pump
- Radiant ceiling

### Hot water system :

- Heat pump

### Cooling system :

- Geothermal heat pump
- Radiant ceiling

### Ventilation system :

- Double flow heat exchanger

### Renewable systems :

- Heat pump (geothermal)

Renewable energy production : 54,65

### Solutions enhancing nature free gains :

The architectural design of the project takes into account natural ventilation in summer and adequate sunshine in winter. The direction of the building is south. Body shape coefficient, floor spacing and window wall ratio meet the requirements of national

## Smart Building

### BMS :

Public device monitoring subsystem:

1. Monitoring of life pump should reflect the running state of the pump. Water pump overload center room should be able to alarm; water tank height and liquid level should be able to display and alarm.
2. Sewage pump and rainwater recovery system. Pump running state display; high and low liquid level display and alarm; pump overload alarm.

Air quality monitoring system:

This project sets up CO monitoring device in underground garage linkage with exhaust system. It is controlled by intelligent BA system. When the detected CO concentration exceeds 20mg/m<sup>3</sup>, the alarm is given and the exhaust system is automatically started to ensure a safe underground garage environment.

Metering device:

Water meters, electricity meters and gas meters are set up separately.

### Users' opinion on the Smart Building functions :



According to the seller, Landsea screen system real-time display temperature, humidity, PM2.5, formaldehyde, VOC and other indicators, integrate outdoor climate indicators, property information, visual intercom and intelligent control. Indicators are transmitted to the backstage and client mobile terminals through mobile interconnection technology, linked with mobile APP, remote control. It also has intelligent lighting scene, curtain control and other expansion functions. After using it, we are satisfied with the system, which fully meets the personalized needs of our customers.

## Environment

### Urban environment

The public supporting categories inside and outside the community include: education, medical and health, cultural and sports, commercial services, community services, administrative management, a total of 6 kinds of public service facilities. It can effectively meet the needs of residential residents.

The project site contains 10 high-rise residential buildings, and a total of 6 supporting commercial buildings with C1~C6#, commercial facilities open to the surrounding residents after business. Among them, C6 # building contains property office and fire control room, and six supporting commercial buildings can effectively meet the basic living needs of residents.

No paper store is 167 meters away from the project.

The project is about 800 meters away from Tianhe Road Station of Metro Line 7. There is also Ninghe Intercity Bus on the north side of the district, which is convenient for residents to travel.

### Land plot area

Land plot area : 55 666,60 m<sup>2</sup>

### Green space

Green space : 7 589,76

### Parking spaces

- ▲ Parking location: underground garage
- ▲ Layer number: 2
- ▲ Total number of parking spaces: 1413
- ▲ Per capita parking space: 0.376

#### ▲ Smart system:

1 Parking lot management system consists of: license plate recognizer, automatic car stopper, ground sense detector, ground sense coil, charge display screen, ACS system management software, server, etc.

2 System settings: the entrance and exit of the West Gate adopt the one-in-one-out mode, and the entrance and exit of the East Gate adopt the one-in-one-out mode. The license plate recognition system is adopted in the system.

3 The import and export are connected and the data are shared so as to facilitate in-field vehicle query and other relevant data processing.

4 System function: When the vehicle arrives at the entrance of the parking lot, the special license plate recogniser at the entrance captures the entrance picture of the vehicle, carries on the license plate recognition analysis at the front end, and obtains the license plate recognition result, uploads the license plate to the data center, if the license plate is a white list user (that is, a long-term user), the license plate recogniser controls the road gate to open and release. OK, the vehicle will enter normally without charge. If it is a temporary user, the system records the license plate information and arrival time, and the camera controls the road gate to open and release the vehicle.

## Products

### Product

#### Wood's Air Purification System

<http://www.woods-china.cn>

#### Product category :

The Wood 's pipeline filter uses ion charging auxiliary technology to attract and catch particulates in the air. With ion charging technology, particles will be negatively charged when air enters the filter. Charged particles are attracted by surfaces with opposite charges, i.e. trapped by an Active ION HEPA filter.

In addition to its excellent purification capability, Wood's exclusive Active ION HEPA filter mesh features ultra-low energy consumption and ultra-low noise. The filter is precharged in the manufacturing process and is more porous than the conventional filter. This characteristic allows the air to pass through the mesh almost without resistance and the particulate matter in it is trapped by the mesh. The direct advantage of using a loose texture filter screen is that it does not have to use a large size, high energy consumption, large noise fan to drive air through the filter. Because air resistance through the Active ION HEPA filter is very small,

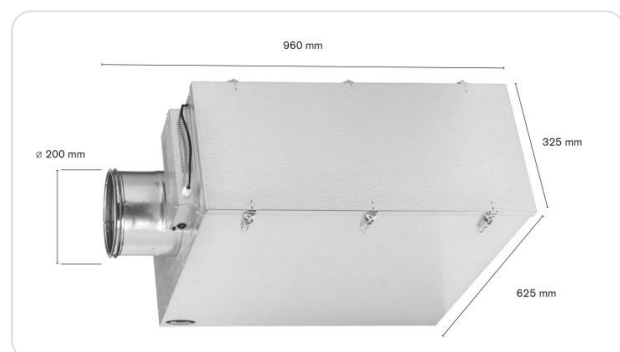

Wood's can use smaller fans, lower energy consumption, and lower noiseActive ION HEPA. The filter screen also ensures better filtering because almost no air flows around the filter frame. It is a common risk for conventional dense screens and air flow around them because the airflow always chooses the path with the least resistance.

Designer: Wood's pipe filter not only has excellent air filtration capacity (PM2.5 filtration efficiency > 99.5%), but also is very energy-saving, quiet operation, low filtration resistance, standard Action HEPA bag filter, can be used as an independent purification system. The Wood's air purification system is developed and manufactured in Sweden using Swedish patented technology. It is complete in Sweden from environmentally friendly metal enclosures to core filters to final product assembly. It is of good quality and durable.

Construction worker: Wood's filters can be easily installed in the existing ventilation system, placed in the ceiling, easy to install.

Users: When the fresh air system is equipped with filters, we don't have to worry about air pollution. We feel that the indoor air is very fresh.

---

## Ceiling coil

108

<http://www.landsea.cn>

### Product category :

The utility model relates to a ceiling coil pipe whose main body is buried in a concrete floor, whose two ends expose a concrete floor and are connected to a water divider and a water collector respectively, with a pipe diameter range of 20-40 mm. During installation, the main body of the pipe body of the ceiling coil pipe can be poured into the concrete floor. After pouring the concrete floor, the two ends of the exposed ceiling coil pipe can be connected to the water distributor and the water collector respectively to complete the installation. When in use, the hot and cold water from the air-conditioning center machine room is distributed to the roof coils of each room for heating or cooling, and then collected back to the air-conditioning center machine room through the water collector. In this process, the hot and cold water in the roof coils of each road is exchanged with the concrete floor first, and then with the concrete floor. Radiation and heat conduction to indoor air, thereby regulating indoor air temperature.



Designer: The roof coil of the utility model changes its routine and ingeniously buries the main body of the air-conditioning coil in the concrete floor, thereby enlarging the coil pipe diameter, thereby avoiding the phenomenon of easy blockage after long-term use. And even if it is blocked, the main body of the large diameter coil pipe is easy to maintain.

Construction worker: The ceiling coil is simple in structure and easy to install.

Users: The indoor temperature is relatively uniform and the air flow inside the room is small. The human body feels comfortable.

<http://www.landleaf-tech.com/>

Product category :



In order to make residents feel safer, healthier, more convenient and more comfortable, the Department of the project is equipped with a combination of indoor environmental monitoring systems, visual intercom and security systems, HVAC control systems, integrated home systems and other subsystems to form the whole house information system (Landsea screen). The system adopts RS485 communication acquisition equipment to detect the air quality. The whole room information center uses self-developed software to collect the air quality data (temperature and humidity, TVOC, CO2, PM2.5, formaldehyde, etc.) detected by the sensor module, and displays them in the information center of the upper room in real time. The whole room information center collects the detection of the sensor module in real time. The test data can be sent to the server through the network, and the user can access the data through app.

Designer: Landsea screen is a multi-functional high-definition smart magic mirror screen, wired network connection, mobile phone linkage, there are three specifications: 10 inches, 15 inches, 21 inches, can achieve personalized household control, humanized intelligent control, all-round real-time monitoring, all-round security guard, mobile remote control.

Construction worker: Easy installation.

Users: Landsea screen makes the indoor air quality visualization, let us live at ease, while the screen appearance is high-end, interactive interface highlights personalized operation, the experience is great.

## Costs

### Construction and exploitation costs

Renewable energy systems cost : 75 000 000,00 ¥

Cost of studies : 1 000 000 ¥

Total cost of the building : 200 000 000 ¥

### Energy bill

Forecasted energy bill/year : 6 000 000,00 ¥

Real energy cost/m<sup>2</sup> : 29.62

Real energy cost/Dwelling : 5106.38

## Building Environmental Quality

### Building Environmental Quality

- indoor air quality and health
- acoustics
- integration in the land
- mobility
- products and materials

## Health and comfort

### Water management

Consumption from water network : 321 513,00 m<sup>3</sup>

Consumption of harvested rainwater : 10 482,40 m<sup>3</sup>

Water Self Sufficiency Index : 0.03

Water Consumption/m<sup>2</sup> : 1.59

Water Consumption/Dwelling : 273.63

Drinking water quality and control: Drinking water conforms to the "drinking water hygiene standard" (GB5749-2006) requirements. The living pump house is on the ground floor, with an effective volume of 150 tons, divided into two grids. The manhole cover of the living water tank is tightly closed and locked, and 18 mesh stainless steel mesh net cover is wrapped around the orifice of the ventilation pipe and the overflow pipe.

Water quality and control of non-traditional sources: The rainwater supply pipeline is separately set up from the drinking water pipeline. No water faucet can be installed on the rainwater supply pipe, and the following measures shall be taken to prevent misuse, misuse and misdrinking: The outer wall of the water supply pipe is painted green or marked. When a water intake is set up, a lock or a special opening tool shall be provided; the pool (tank), valve, water meter, water hydrant and water intake shall be marked with obvious "rain water".

Rainwater effluent is monitored with control index.

Water quality monitoring system: regular sampling of water samples sent to testing institutions for testing.

## Indoor Air quality

Indoor CO2 test concentration mg/m3 0.041

Indoor formaldehyde test concentration mg/m3 0.022

Indoor TVOC test concentration mg/m3 0.26

Indoor Benzene concentration mg/m3 0.001

Indoor PM2.5 test concentration  $\mu\text{g}/\text{m}^3$  30

## Comfort

### Health & comfort :

Indoor mean temperature in January 22      Indoor mean humidity 40%

Indoor mean temperature in July 26      Indoor mean humidity 50%

### Acoustic comfort :

The indoor background noise level of this project has reached the average value of the low limit and high standard limit in the current national standard GB 50118. The performance of air sound insulation between components and adjacent rooms meets the low limit requirement of the current national standard GB50118.

This project aims to reduce noise interference through reasonable arrangement of indoor space layout. The elevator room and well path are not adjacent to each other, and there are quiet requirements for room layout. Noise elimination devices include noise elimination, sound insulation, vibration isolation and vibration isolation. All kinds of water supply and drainage machinery and equipment preferred low speed and low noise equipment. The same floor drainage is adopted for the floor toilet drainage, and the corresponding noise elimination and shock absorption measures are adopted.

## Carbon

## GHG emissions

Building lifetime : 70,00

### Reasons for participating in the competition(s)

Under the background of the rapid development of low-carbon environment-friendly building, green building has created a good living environment for human beings while effectively reducing environmental pollution and saving land, water, energy and other resources. Since its inception, Landsea Real Estate has positioned itself as a high-quality, high-starting point of business philosophy, with its own development to drive the region's green, ecological cause of continuous progress.

Nanjing Langshi Aoheyuan Xihuafu is targeted at the three-star goal of green building, advocating making people-oriented, livable and eco-green buildings according to local conditions. In the design process, the building energy-saving, water-saving, material-saving, land-saving and indoor environment are considered comprehensively, which meets the relevant requirements of green building. Advanced computer simulation technology is applied to simulate the energy consumption and air flow distribution of HVAC in order to achieve the goals of improving people's living comfort, saving energy and reducing consumption and beautiful environment. Meanwhile, rainwater collection and reuse system is set up to respond to the call of national sponge urban design. The landscape highlights the LID design and truly reflects the practical significance of green building. Green building is the first energy-saving building. On the basis of green energy-saving, the first concern of this project is indoor health. The removal efficiency of PM2.5 is as high as 95%, and the indoor formaldehyde control standard is less than 0.03 mg/m<sup>3</sup>. The second concern is indoor comfort, radiation air conditioning system has no sense of blowing, horizontal and vertical temperature difference is less than 3 degrees Celsius, humidification and dehumidification through fresh air system, humidity control 30% - 70%. The third concerns intelligent life, Landsea screen system is not only a security system, but also real-time display of indoor environmental parameters, human-computer interaction interface, highlighting the sense of technology.

### Building candidate in the category

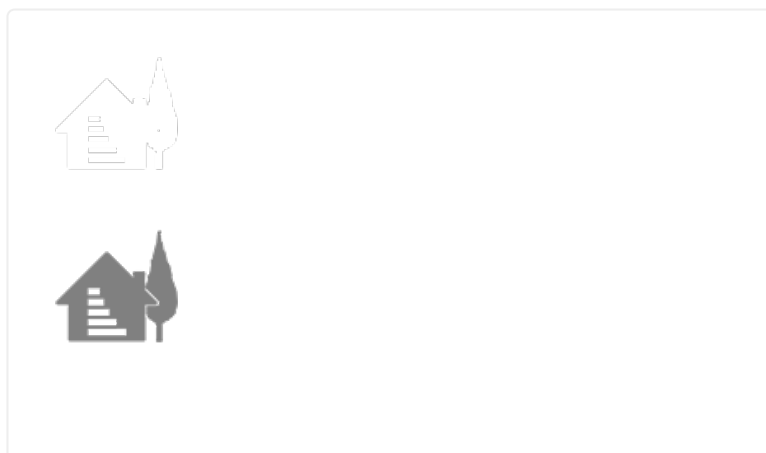

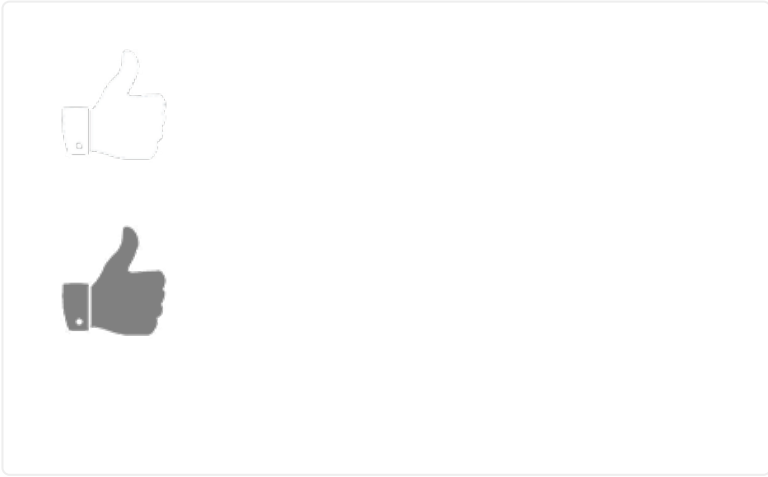
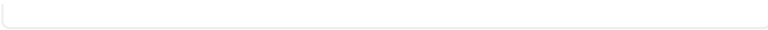

Date Export : 20230329175301